



TBBS1850-GD



TBBS900-GD

Precision's Back Bar Storage cabinets combine great looks with the latest, hassle free energy saving refrigeration technology. These cabinets make a stylish addition to any bar concept with numerous exterior finishes, as well as door and handle options, to compliment any interior decor.

These back bar fridges are a high impact sales tool as well as being a solid, reliable piece of equipment with robust 43°C ambient refrigeration systems. A matching 600mm wide Glass Froster is also available within this product range.

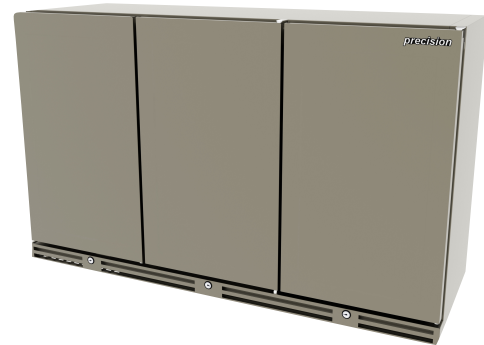

TBBS1350-SD

**Key Features:**

- Stainless Steel Exterior
- Mirrored Stainless Steel Interior
- Front Breathing & Venting Refrigeration System
- Glass Doors As Standard
- LED Lighting (6400K Daylight White)
- Adjustable Perforated Stainless Steel Shelves
- R290 Refrigerant
- 40mm Zero ODP Polyurethane Insulation
- +1/15°C Refrigerator Temperature Range
- Electronic Controller With LED Display Discreetly Positioned Inside The Cabinet For Ease Of Access
- Door Locks Fitted As Standard
- Rifle Bore Coated Evaporators
- Stylish "Hidden" Door Handle
- Hi / Lo Audio Visual Temperature Alarms
- Maintenance Free Condenser
- Levelling Feet
- Waste Heat Recovery Condensate Vaporiser System

**Options:**

- Solid Doors
- Sliding Glass Doors +14mm Depth
- Sliding Solid Doors +14mm Depth
- Coloured Plastisol Steel Door and Grill
- Coloured "Rimex" Steel Door and Grill
- Painted Door and Grill (To Any RAL Number)
- 845mm Height
- 800mm Height
- Wooden Door Options - Consult Factory
- Exterior Cladding - Consult Factory
- Precision Connect

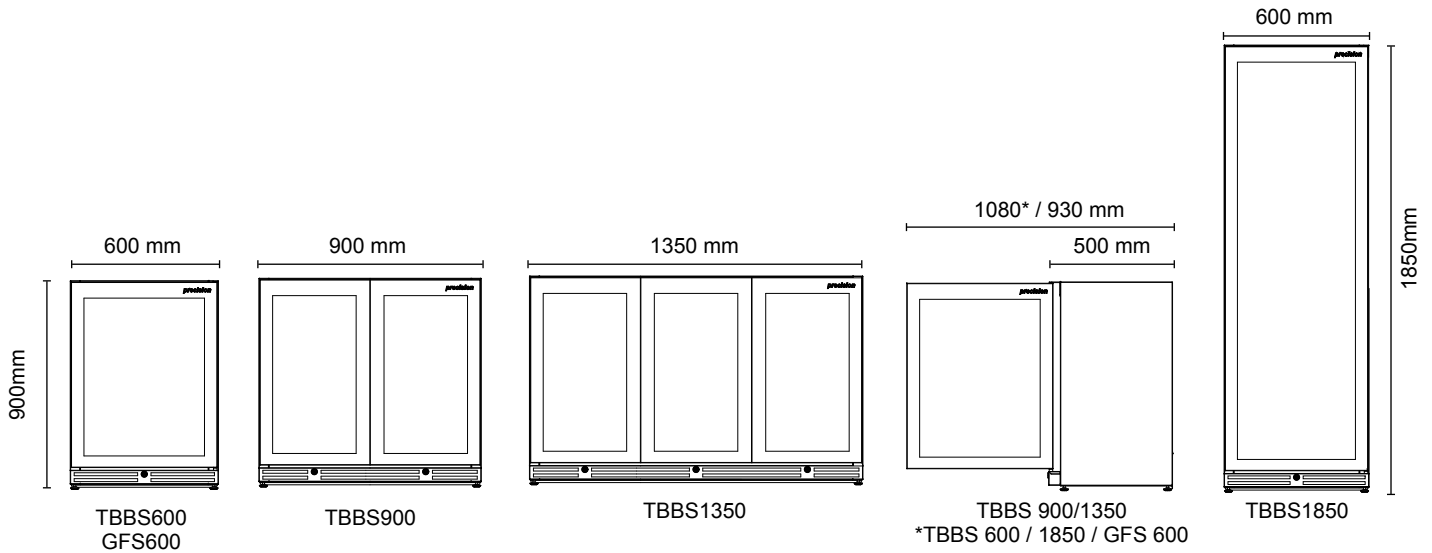

Model	TBBS600	TBBS900	TBBS1350	TBBS1850	GFS600
Type	Bottle Cooler	Bottle Cooler	Bottle Cooler	Bottle Cooler	Glass Froster
Material	ST/ST Int/Ext	ST/ST Int/Ext	ST/ST Int/Ext	ST/ST Int/Ext	ST/ST Int/Ext
Shelf Size (mm)	348x502	306x402	306x418	348x502	348x502
Number of Shelves	2	4	6	4	2
Max Capacity (330cl Bottles)	137	194	309	326	N/A
Temperature Range	+1 / +15°C	+1 / +15°C	+1 / +15°C	+1 / +15°C	-10 / -22°C
Exterior WxDxH (mm)	600x500x900	900x500x900	1350x500x900	600x500x1850	600x500x900
Weight (KG)	55	71	95	95	55
Refrigerant / GWP	R290 /3	R290 /3	R290 /3	R290 /3	R290 /3
Refrigeration Watts (+45°C Condensing)	306	306	306	306	208
Evaporating Temp	-5°C	-5°C	-5°C	-5°C	-30°C
Heat Rejection Watts*	459	459	459	459	438
Power	220 / 50 / 1	220 / 50 / 1	220 / 50 / 1	220 / 50 / 1	220 / 50 / 1
Running Amps	1.33	1.5	N/A	N/A	N/A
Total Electrical Load - kW	0.29	0.33	N/A	N/A	N/A
Energy Consumption / 24hrs - kWh**	2.04	4.46	N/A	N/A	N/A
Energy Consumption / Year (AEC) - kWh**	745	1628	N/A	N/A	N/A
Energy Efficiency Class**	A	B	N/A	N/A	N/A

\* Heat Rejection is taken at the listed evaporating and condensing condition. Watts is calculated by taking the total power of the cabinet.

\*\* Tested to ISO 23953 GEMS Class: M1

We are constantly innovating and improving our products. Please always check our website for the most up-to-date version of this spec sheet