

MCU223-UDD-850

Precision's durable all stainless steel GN2/3 counters have been designed to provide commercial caterers with reliable, energy and cost efficient refrigerated storage solutions. Proudly designed in the UK, these counters are capable of meeting the highest demands of commercial kitchens all around the world.

At just 520mm deep, these refrigerated counters provide a practical and flexible solution when space is at a premium.

Key Features:

Stainless Steel Interior & Exterior

Front Breathing & Venting Refrigeration System
Designed To Operate In 43°C Ambient

GN 2/3 Shelving System

Anti-Drip Worktop

Built-In Air Duct For Even Temperature Distribution

R290 Refrigerant

Zero ODP Injected Polyurethane Insulation - 60mm

-2 / +4°C Refrigerator Temperature Range

Electronic Controller With Easy Read LCD Screen

Hot Gas Defrost

Door / Drawer Locks Fitted As Standard

Rifle Bore Coated Evaporators

Integrated Flush Door Handle

Hi / Lo Audio Visual Temperature Alarms

Condensing Unit Safety System To Protect
Compressor From Blocked Condensers

Self Closing Doors

Heavy Duty Brake & Swivel Castors

Waste Heat Recovery Condensate Vaporiser System

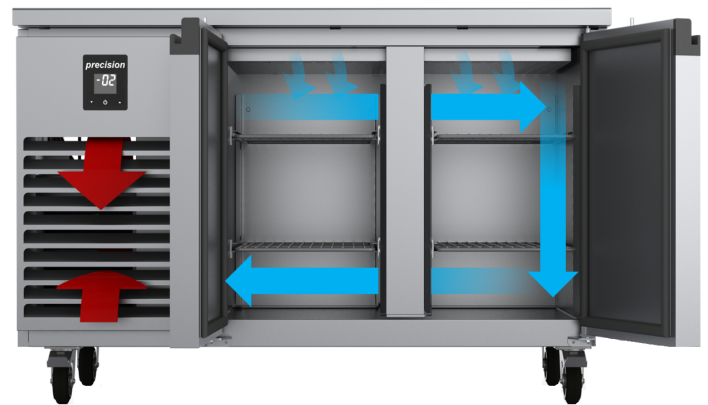

Front Breathing & Venting Refrigeration System - No side/rear/top/bottom ventilation required - Perfect For Plinth Mount Applications

Options:

Bank of 2 Drawers - H - (200/200mm Depth)

Bank of 3 Drawers - T - (100/130/130mm Depth)

Remote Units - R (Width reduces by 120mm)

Raised Pan Grid - PG / Countertop Pan Wells

Biscuit Worktop - Lowers Height By 20mm

Low Profile Castors - Lowers Height By 25mm

Plinth Mount - Lowers Height to 740mm

Adjustable Legs - Increases Height to 910mm Max

ST/ST Back / Splashback

Right Hand Condensing Unit

Extra Shelves / Slides

Precision Connect

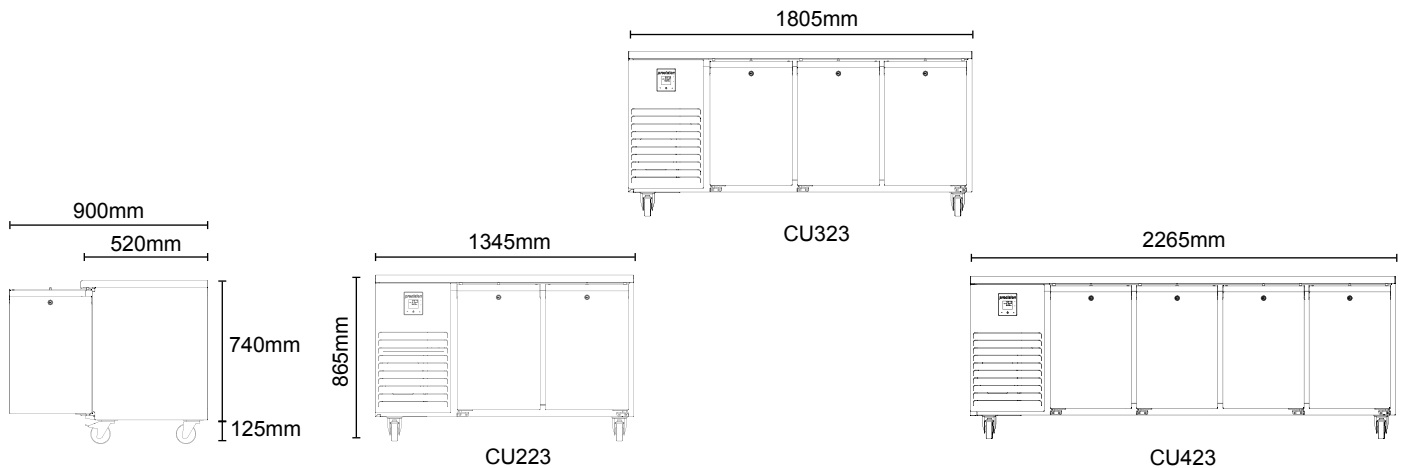

Model	MCU223	LCU223	MCU323	LCU323	MCU423
Type	Refrigerator	Freezer	Refrigerator	Freezer	Refrigerator
Material	ST/ST Int/Ext	ST/ST Int/Ext	ST/ST Int/Ext	ST/ST Int/Ext	ST/ST Int/Ext
Shelf Size	GN2/3	GN2/3	GN2/3	GN2/3	GN2/3
Number of Shelves	4	4	6	6	8
Max Number of Shelves (100mm Spacing)	10	10	15	15	20
Temperature Range	-2 / +4°C	-18 / -22°C	-2 / +4°C	-18 / -22°C	-2 / +4°C
Exterior WxDxH (mm)	1345x520x865	1345x520x865	1805x520x865	1805x520x865	2265x520x865
Net Usable Volume (litres)	115	115	173	173	236
Weight (KG)	110	115	125	130	145
Refrigerant / GWP	R290 / 3	R290 / 3	R290 / 3	R290 / 3	R290 / 3
Refrigeration Watts (+45°C Condensing)	373	449	373	449	373
Evaporating Temp	-10°C	-30°C	-10°C	-30°C	-10°C
Heat Rejection Watts*	609	955	622	1028	634
Power	220 / 50 / 1	220 / 50 / 1	220 / 50 / 1	220 / 50 / 1	220 / 50 / 1
Running Amps	1.4	1.72	1.5	3.4	1.65
Total Electrical Load - kW	0.31	0.38	0.33	0.75	0.36
Energy Consumption / 24hrs - kWh**	1.33	4.89	2.14	6.86	3.34
Energy Consumption / Year (AEC) - kWh**	485	1785	781	2504	1219
Energy Efficiency Class**	A	D	B	D	D

* Heat Rejection is taken at the listed evaporating and condensing condition. Watts is calculated by taking the total power of the cabinet.

** Tested to BS EN ISO 22041

We are constantly innovating and improving our products. Please always check our website for the most up-to-date version of this spec sheet